

Dante® Network Intercom



BEATRICE R16
Sixteen Channel Rackmount Intercom

Highlights

Dante® and AES67 Compliant

Simple To Use

Intelligible Loudspeaker

48kHz Crystal Clear Digital Audio

Mains/ PoE Powered

Low Noise Microphone Amp

Overview

The GlenSound BEATRICE R16 is a versatile and fully featured 16 channel rackmount intercom with crystal clear audio designed for broadcast, theatre and professional audio applications.

It is part of our Beatrice intercom system that utilises the reliable and proven Dante network audio transmission protocol to allow real time distribution of uncompressed audio across standard networks. It is also AES67 compliant. As such the BEATRICE R16 is fully compatible with other manufacturers' equipment using the Dante® and/ or AES67 protocols.

This 1RU rackmount intercom was designed to be very easy to use for the operator and simple to set up for the technician. It includes all the basic functionality required for small intercom systems and none of the overly complex installation requirements normally associated with large systems.

Intercom & Talkback



BEATRICE R16

Sixteen Channel Rackmount Intercom

Features



- 16 Channels Of Intercom**

One single user connected to the unit can listen to and communicate with 16 separate locations on the network. Depending upon how the Dante network has been routed the incoming audio circuits and outgoing circuits can be different locations.
- Dante Routing & Partyline**

Audio routing to/ from other devices is set up using Dante controller which allows for point to multipoint routing on outgoing circuits (but only 1 single incoming circuit for each of the 16 channels). Therefore we've included an inbuilt fixed ratio 11 input 11 output mixer matrix with inputs and outputs connected directly to the Dante / AES67 network which allows for setting up partyline and group circuits.
- Onboard Mic & External Mic Input**

A good quality, clear sounding microphone amplifier designed for communication purposes is fitted which also has the benefit of a compressor/ limiter circuit to help keep levels and intelligibility consistent even when the operator gets overly excited. This microphone amp has two microphone sources, either the inbuilt front panel mounted electret capsule which provides good voice intelligibility from normal working distances, or a balanced XLR input for connecting external gooseneck microphones. Twelve Volt Phantom power is also available and can be turned on/ off as required via an internal link.
- High Output Intelligible Loudspeaker**

What's the point of an intercom unit if the onboard speaker is so cheap that you can't understand what is being said to you? We tried hundreds of different drive units before settling on the one used in the Beatrice R16. We chose it because it had a much cleaner sound and better frequency response for vocals than any other speaker on the market that would fit in a 1RU subrack.
- User Programmable Talk Switches**

The Beatrice R16 can have each individual speak switch set to the way that you prefer to work, be it latching, momentary or intelligent lever key.

Intercom & Talkback



Features

- **Mains or PoE Powered**

An inbuilt wide range switch mode mains power supply is fitted for powering the Beatrice R16. It is terminated with a standard IEC plug, making it easy to plug in wherever you are in the World.

The unit can also be powered via the Ethernet cable by standard PoE (Power over Ethernet) on either of the copper Ethernet ports. The PoE power can be supplied by an external PoE switch or a midspan power injector.



- **Redundant Twin Copper & Twin Fibre Ethernet Interface**

When ultra reliable communications is needed for the utmost important jobs glitch free redundant network circuits can be set up using the primary and secondary Dante network ports.

There are 2 copper Ethernet ports on RJ45s and also 2 fibre Ethernet ports presented as SFP slots (SFP modules not included). Redundant networks can be set up across any of these ports. These ports can also be setup as a network switch.

- **GPIO**

A solid state relay output is provided and is triggered when any speak key is on (useful for dimming external loudspeakers or red light controls).

In total there are 12 loop closure inputs. 10 of these control the first 8 talk keys and talk to group and talk to all.

The other 2 loop closure inputs provide internal & external LS cuts.

- **IFB/ AUX Sources**

Four different IFB/ AUX audio sources are received from the Dante network. Each of the four sources is associated with four outgoing talkback channels. If audio is routed to the(se) IFB/ AUX sources in the network then they are mixed in with their associated outgoing talkback channel circuit.

If a talkback key is on then the associated IFB/ AUX source is ducked by a user definable amount. If the talkback is not on then the IFB/ AUX source is routed to the channel's output with unity gain.

IFB/ AUX sources are very useful for distributing programme audio around an intercom setup whilst the ducking facility allows talkback to be heard over it.

Intercom & Talkback





Microphone Level Meter

An eight LED front panel multipurpose indicator is used to indicate the outgoing microphone level.

- Channel Input and Output Gain Controls**
 For maximum flexibility gain can be applied to incoming audio signals and outgoing signals separately. A row of LEDs indicate the current gain setting when a channels input or output is being adjusted.
- Monitor**
 All incoming talkback channels are mixed together to the headphones/ loudspeakers.
- Presence Indication**
 Front panel LEDs located next to the talk switches are used to indicate the presence of incoming audio on that channel. When audio is detected on the channel the LED is illuminated, the LED then stays on for a short period after the incoming audio stops to help the operator identify who has been talking to them.
- 4-Wire Connectivity**
 Two traditional analogue 4-wire circuits can be connected to two of the R16's intercom channels by utilising the versatile analogue inputs and outputs.
- Speak To All and Speak To Group**
 Two useful front panel controls are fitted. When pressed, the 'Speak To All' button will enable the operator to talk to all the outputs simultaneously, and the 'Speak To Group' button allows the operator to talk to an easily assignable set of outputs.



Speaker Output

As well as the front panel internal loudspeaker a balanced analogue output is provided for connecting to an external powered loudspeaker.





- Local Input and Output Circuits**
For increased versatility there are 2 local balanced analogue audio inputs and 2 local balanced analogue outputs. The inputs are routed directly to two output channels on the Dante/ AES67 network. The outputs are fed directly from two input channels from the Dante/ AES67 network.
- Mixer Matrix For Partyline**
For setting up simple groups and partyline circuits that could not be achieved via Dante controller or your AES67 router, an inbuilt fixed ratio mixer is supplied. It has 11 audio inputs direct from the network and 11 mix outputs to the network.

MIX OUTPUT		SUM OFF
<i>Dante Output Channel No:</i>	<i>Default Name in Dante Controller:</i>	<i>Dante Receiver Channel Nos:</i>
22	"Sum of 23 to 32"	23 to 32
23	"Sum of 23 to 27 "	23 to 27
24	"Sum of 28 to 32"	28 to 32
25	"Sum of 23 to 25"	23 to 25
26	"Sum of 26 to 29 "	26 to 29
27	"Sum of 30 to 32 "	30 to 32
28	"Sum of 23 & 24 "	23 and 24
29	"Sum of 25 & 26 "	25 and 26
30	"Sum of 27 & 28 "	27 and 28
31	"Sum of 29 & 30"	29 and 30
32	"Sum of 31 & 32 "	31 and 32



Intercom & Talkback



Intercom & Talkback

Block Diagram of Audio Sent to The Dante®/ AES67 Network

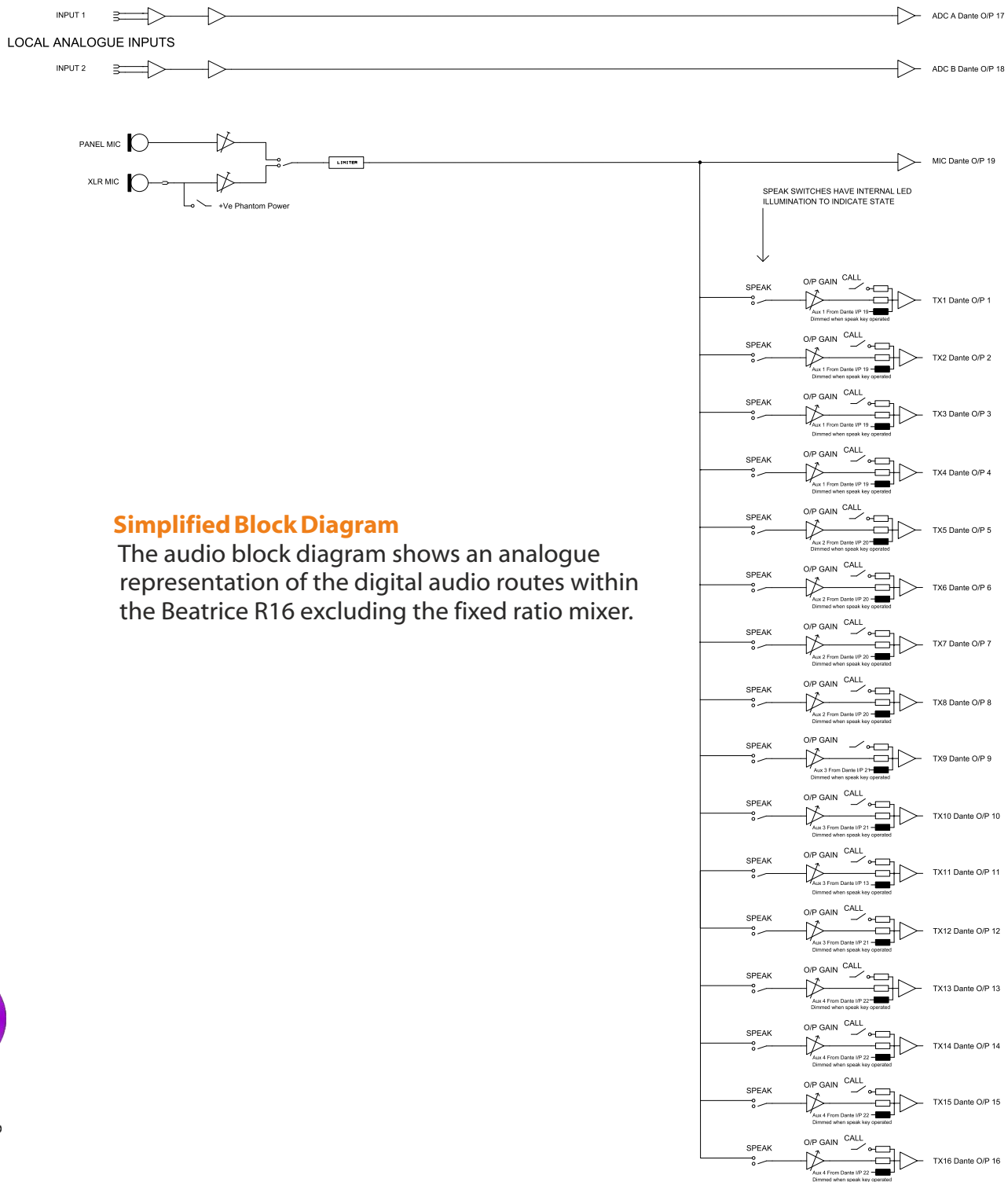

Simplified Block Diagram

The audio block diagram shows an analogue representation of the digital audio routes within the Beatrice R16 excluding the fixed ratio mixer.



Intercom & Talkback

Block Diagram of Audio Received From The Dante®/ AES67 Network

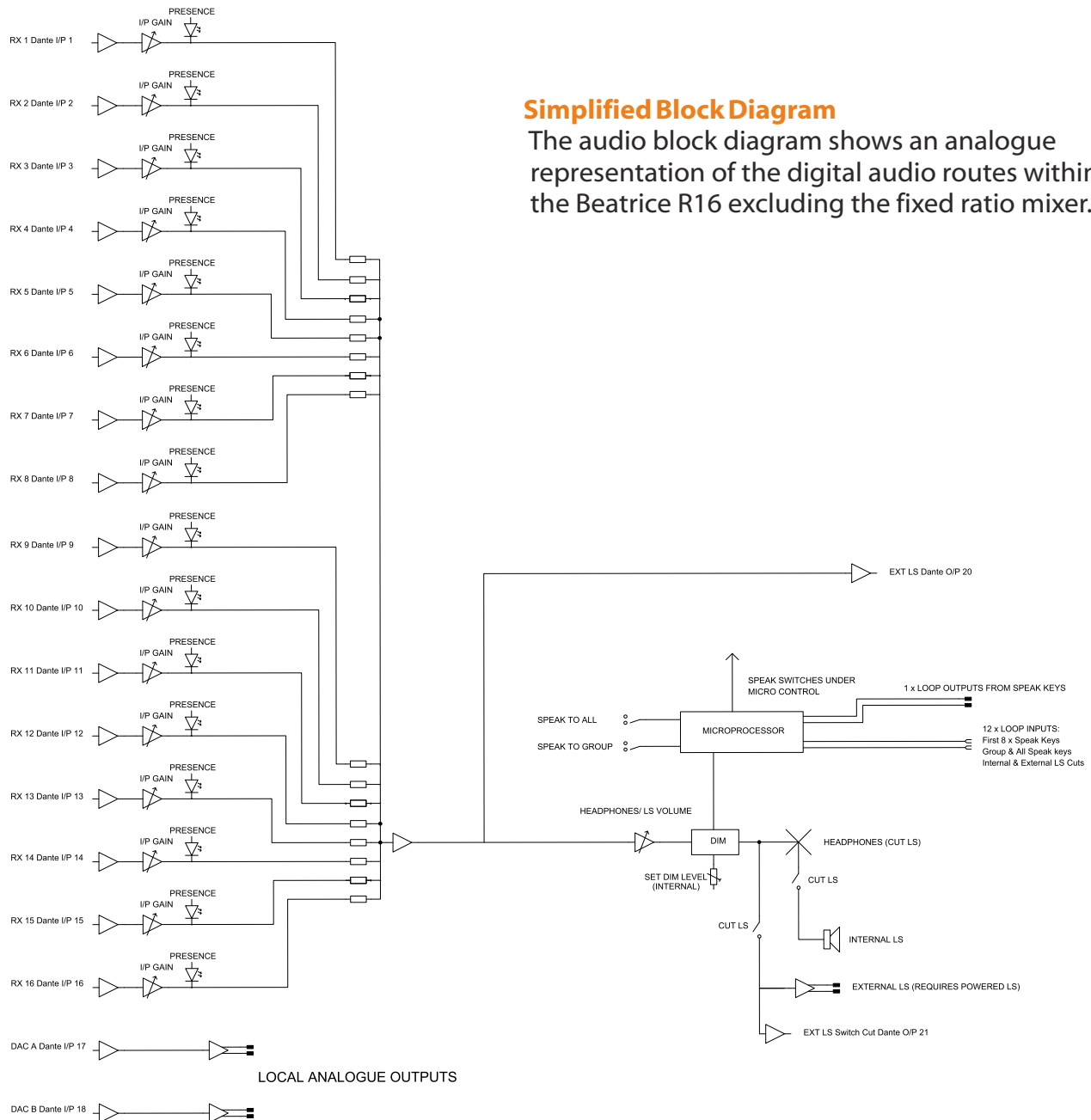

Calling Facility Note:

Please note that unlike the lower channel count Beatrice units (B1, B2, B4, D4, R4, D8, D8+, P1, P2 and R8) the 16 key DIM units D16 and R16 do not support inband calling.

Specification

NETWORK/ Dante®

Physical Interface

2 off RJ45
2 off SFP slots

Audio Sample Frequency

48k

Transfer Rate

1000 Mbps

Dante® Chipset

Brooklyn II

Note: suitable for acting as master clock for a network incorporating many Ultimo chipsets

AES67 Compliant

AES67 compliant

PHYSICAL

Mechanics

All aluminium with laser etched panels and light textured black powder coated lid & base

Size

19" wide, 1RU high, 164mm deep

Weight

1.6Kg 3.5lb

Shipping Weight

3Kg

Shipping Size

62 x 42 x 12 cms

Shipping Carton

Rugged export quality cardboard

ENVIRONMENTAL

Operating Temperature

0 to +50 °C (32 to 122°F)

Storage Temperature

-20 to +70 °C (-4° to 158°F)

Relative Humidity

0 to 95% non-condensing

INCLUDED ITEMS

Handbook

Physical A5 (download also available)

RJ45 Network Cable

2 metre Cat5 RJ45plug /RJ45plug cable

Mains Cable

2 metre IEC (UK & Europe Only)

AUDIO

Mic Gain Range

61 to 21dB

Phantom Power

12 Volts (set via internal link)

Equivalent Input Noise

-126dB (20-20KHz RMS A Weighted 150 Ohms)

Headphone Impedance

32 - 1000 Ohms

Max Headphone Output Level

+14dB into 600 Ohms

Headphone Connector

6.35mm (1/4") TRS socket

Band Pass Filter

50Hz to 15kHz

AUX/ IFB Ducking Range

0 to -63dB (set per talkback channel)

GPIO

GPO

Solid State Relays. Wired N'O and N'C

GPI

Logic level pull down to ground to operate

POWER

Mains Voltage

100 - 240 VAC +/-10%

Mains Frequency

50 to 60 Hz

Power over Ethernet (PoE)

May be powered by PoE on either Copper Port

Complies to: IEEE 802.3af-2003

Classification Class 0

Consumption

<15 Watts

Redundancy

Mains & Both PoE supplies are all dioded together for glitch free redundancy

Power On LED

Bright Blue

MIC/ HEADSET OPTION

Standard (Part no: Beatrice R16)

Front Panel 3 pin XLR socket Mic Input

Optional 5 Pin (Part no: Beatrice R16-X5)

Front Panel 5 pin XLR socket Headset Connector

Optional 4 Pin (Part no: Beatrice R16-X4)

Front Panel 4 pin XLR plug Headset Connector

The name **Beatrice** was chosen for our intercom range as she was the love of Dante Alighieri:

'Dante had fallen in love with another, Beatrice Portinari (known as Bice), whom he first met when he was only nine.' Source Wikipedia.

We hope that you will also fall in love with Beatrice.

E & OE